



MP FLEX POST

2.375" HIGH PERFORMANCE FLEXIBLE CHANNELIZER POST

SPEC-MP2 | 06/15/2017

Long Squeeze Short Squeeze Black Cap (or open top)

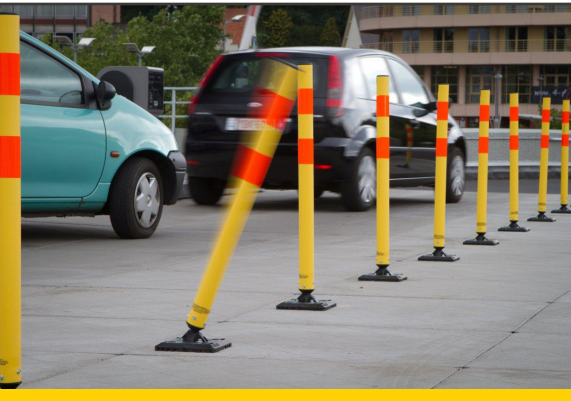

Colors:



SPECIFICATIONS SHEET

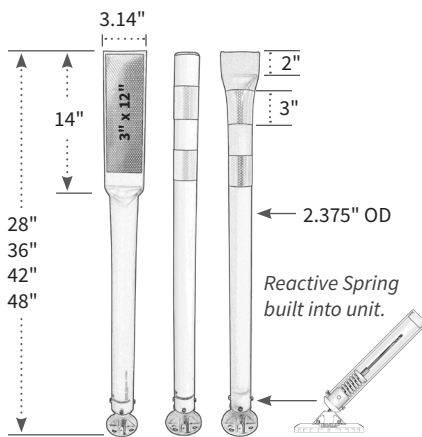

Dimensions

- Outer Diameter: 2.375"
- Standard Post Heights: 28", 36", 42" and 48"
- Short Squeeze: 2" squeeze
- Long Squeeze: 14" squeeze

FEATURES

- Yields Fully upon impact
- Anti-Twist Reactive Spring assembly returns unit to upright position when struck.
- Quick, Easy Installation
- Retro-Reflective sheeting
- Durable HDPE Plastic is resistant to ozone, UV light & hydrocarbons.
- Vivid Integral Color
- MUTCD compliant

SPECIFICATIONS

Post

Material: Flexible HDPE plastic
 Available Colors: White, yellow, orange, red, gray, black or green
 Post Style:

- Long squeeze (14" from top)
- Short squeeze (2" from top)
- Black cap (Black plastic)
- Open top

Reactive Spring

Type: Fixed, quick release or drivable

Reflective Sheeting

Retro-Reflective Sheeting:

- High-Intensity sheeting or
- Diamond grade sheeting

Available Colors: White, yellow, orange, red, green or blue

Included Sheeting:

- **Long Squeeze:** Single sheet 3" x 12" reflective sheet included. (Double-side sheeting available.)
- **Short Squeeze, Black Cap & Open Top:** Two 3in bands included. Custom configurations available.

RECOMMENDED USE

- Ideal when increased visibility and channelization is needed.
- Use for indicating alignment in roadway, atop Tuff Curb® systems, in parking garages and in parking lots.

BASE OPTIONS

Base and base mounting hardware is sold separately.

Surface Mount Base

Fixed or Quick Release Model

- Durable HDPE plastic
- **Colors:** Black, yellow or white
- 8" x 8" x 1"
- Installs with anchors or epoxy

Drivable Base

For In-Ground Installations

- 12-gauge perforated steel tubing
- 2" x 2" x 18"

Impact Traffic Channelizer Curb

Tuff Curb™ or Tuff Curb XLP™

- **Colors:** Yellow, white or Green(XLP)

Office 800.320.3230



www.pacificproductsandservices.com



7323 Lynwood Way
 Highland, CA. 92346

