

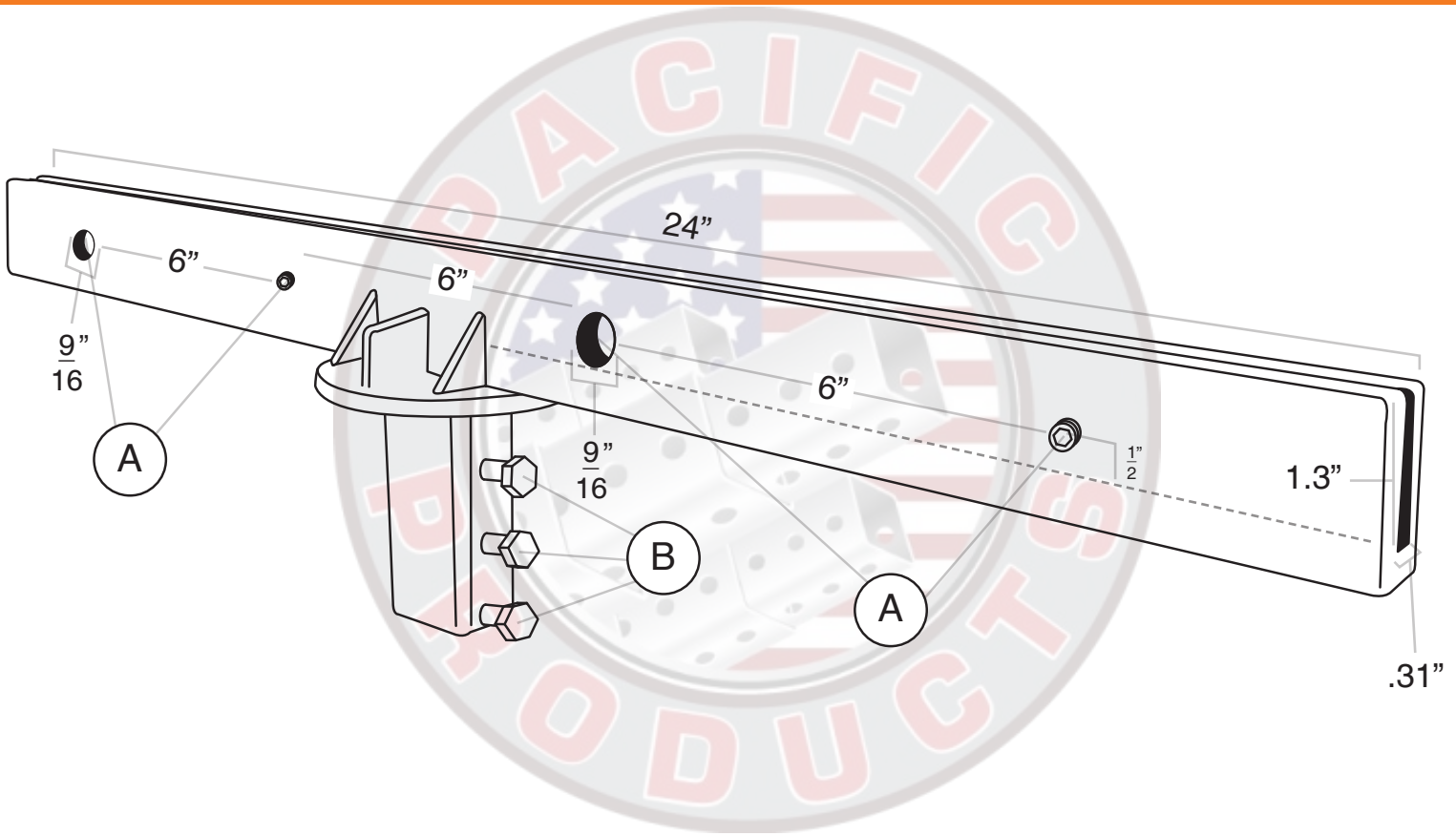

# U-Channel 90° Post Cap 240UCX090

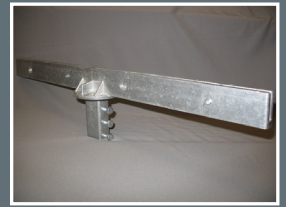

Description	Fasteners	Blade Holder Length	Blade Type	Recommended for Blade Length	Units/Box
<b>90° U-Channel Post Cap</b>  • 90° aligns sign parallel to the U-Channel Post • Weight: 3.45 lbs.	<b>INCLUDED:</b> (A) 5/16" - 18 x 1/2" Set Screw Qty: 4 (B) 5/16" - 18 x 3/4" Hex Bolts Qty: 3  <b>OPTIONAL:</b> • VP Button Head Set Screws B-VPSS51638-MS • 12 point Bolts B-12P51612-AL • VP Button Head Bolt VPBH51634-MS	24"	Extruded	54" and above	10

## INSTALLATION:

- 9/16" clearance holes allow secure and balanced installation
- 25-40 pounds of pressure is sufficient to secure sign
- Fasteners come pre-installed

## QUALITY:

- Die Cast Brackets are cast from high strength aluminum under 400 tons pressure.
- Tensile strength 45,000 P.S.I. tumbled and degreased for smoothness and ease of handling.