

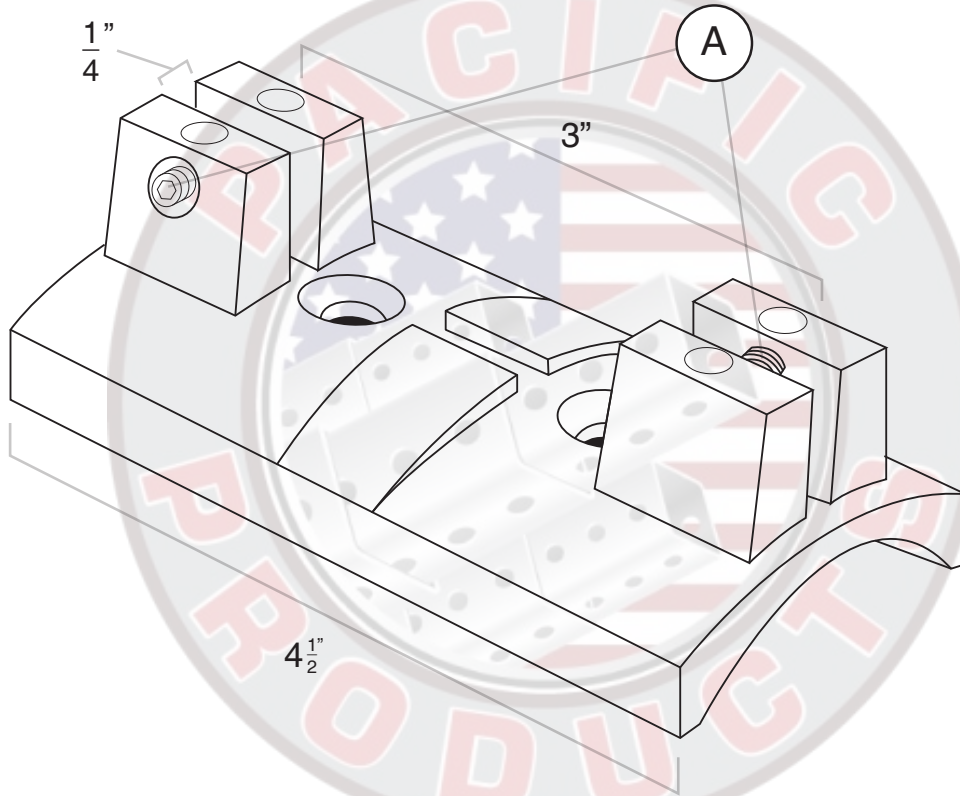

# External Cantilever Wing Bracket

# 412EWB000

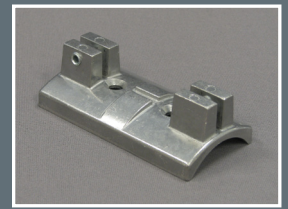

Description	Fasteners	Blade Type	Recommended for Blade Length	Units/Box
<b>External Cantilever Wing Bracket</b> <ul style="list-style-type: none"> <li>• Mount on wall or any post with strapping or leg bolt</li> <li>• Weight: 0.30 lbs.</li> </ul>	<p>INCLUDED:</p> <p>(A) 5/16" - 18 x 1/2" Set Screw Qty: 2</p> <p>OPTIONAL:</p> <ul style="list-style-type: none"> <li>• VP Button Head Set Screws B-VPSS51638-MS               <ul style="list-style-type: none"> <li>• 12 point Bolts B-12P51612-AL</li> </ul> </li> <li>• VP Button Head Bolt VPBH51634-MS</li> </ul>	Flat/Extruded	18" - 30"	100

## INSTALLATION:

- 9/16" clearance holes allow secure and balanced installation
- 25-40 pounds of pressure is sufficient to secure sign
- Fasteners come pre-installed

## QUALITY:

- Die Cast Brackets are cast from high strength aluminum under 400 tons pressure.
- Tensile strength 45,000 P.S.I. tumbled and degreased for smoothness and ease of handling.