

WORKS BARRICADE

WOOD PANELS WITH GALVANIZED LEGS

TD2300 MODEL

NCHRP350 CRASH TEST CERTIFIED
AND MEETS MUTCD STANDARDS



FEATURES:

- Type I and Type II can be purchased as assembled units or component parts. Legs and boards can be purchased separately. All barricade components are completely interchangeable.
- Legs are standard 45" length manufactured using galvanized steel in 12 and 14 gauge thickness.
- Barricades are assembled utilizing 1/4" x 1" galvanized carriage bolts with high bend milspec split lock washers and nuts and are hinged with two 1/2-13 X 1" hex bolts and 1/2-13 nylon locknuts.
- Hinge holes accommodate 1/2" warning light mounting bolts.

COLORS AVAILABLE:

The TD2300 Works Barricades are currently available in White. Three D Traffic Works can manufacture this product to your desired color.

GENERAL INFORMATION:

General information is listed on the reverse side. The measurements provided are intended only as a source of information. They are given without guarantee and are not classified as a warranty. A specification will be sent to you upon request.

- NCHRP350 Approved: WZ-54.
- MUTCD Compliant.



7323 Lynwood Way, Highland, CA. 92346 Tel: (909) 633-1180
email: anthony@pacificproductsandservices.com
web site: www.pacificproductsandservices.com



MADE IN
USA

TD2300 MODEL WORKS BARRICADE WITH WOOD BOARDS AND STEEL LEGS SPECIFICATIONS

- **Folded Dimensions:**
Thickness: 1.81 Inches
Length: 24 to 36 Inches
Height: 45 Inches
- **Plywood Board Thickness:**
1/2 Inch.
- **Weight of Type I Barricade with 14 Gauge Steel Legs:** 15.75 lbs
- **Leg Material:** 14 and 12 Gauge Galvanized Steel Roll Form.
- **Hinge Holes Accept 1/2" Warning Light Mounting Bolts.**
- **Board Colors:** White
- **All Sheeting Complies with ASTM 4956.01 requirements.**

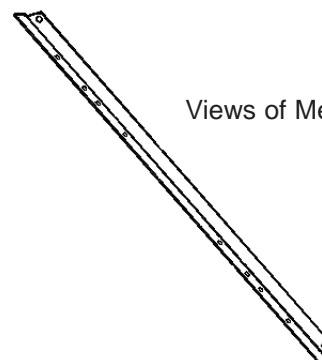
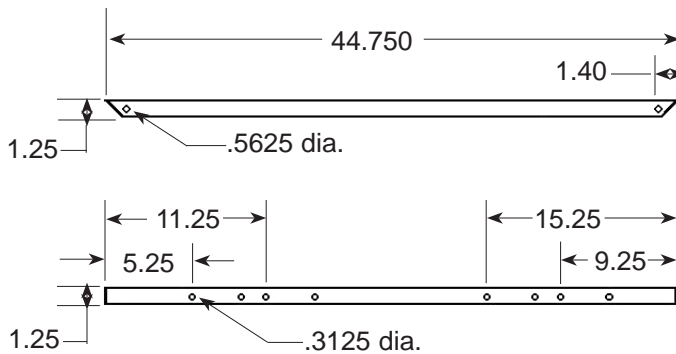
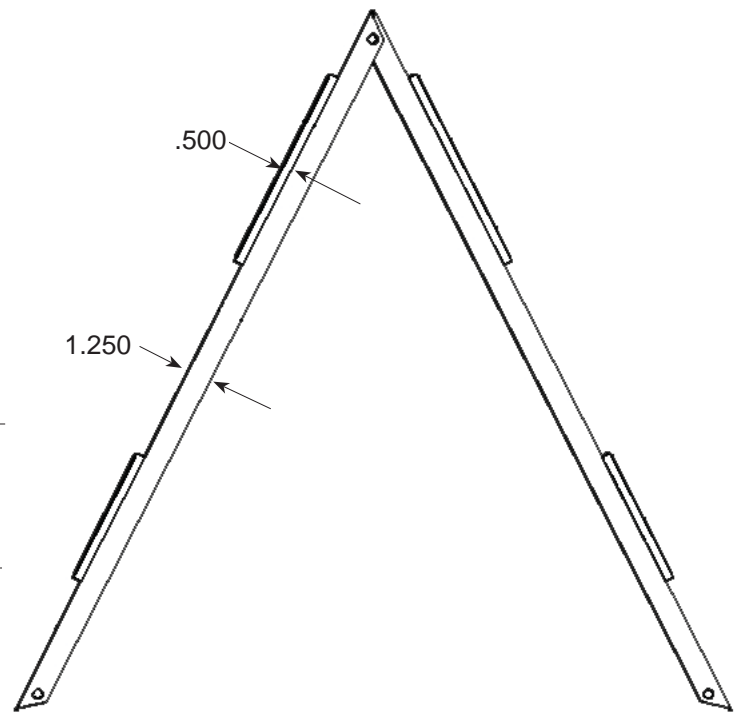
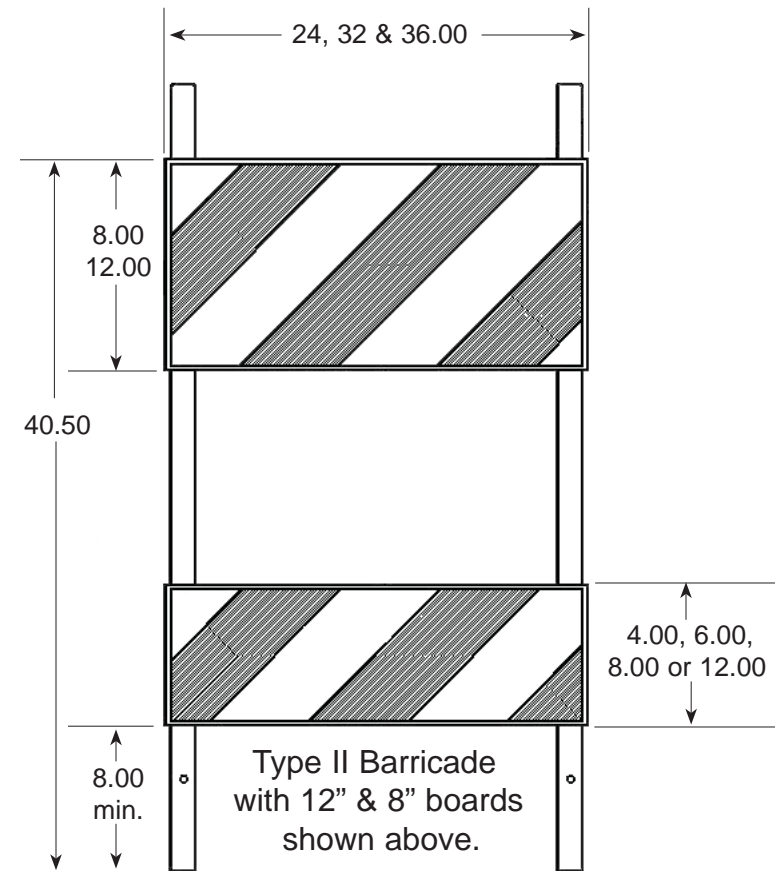

Views of Metal Barricade Legs